

# DOCUMENTACIÓN TÉCNICA

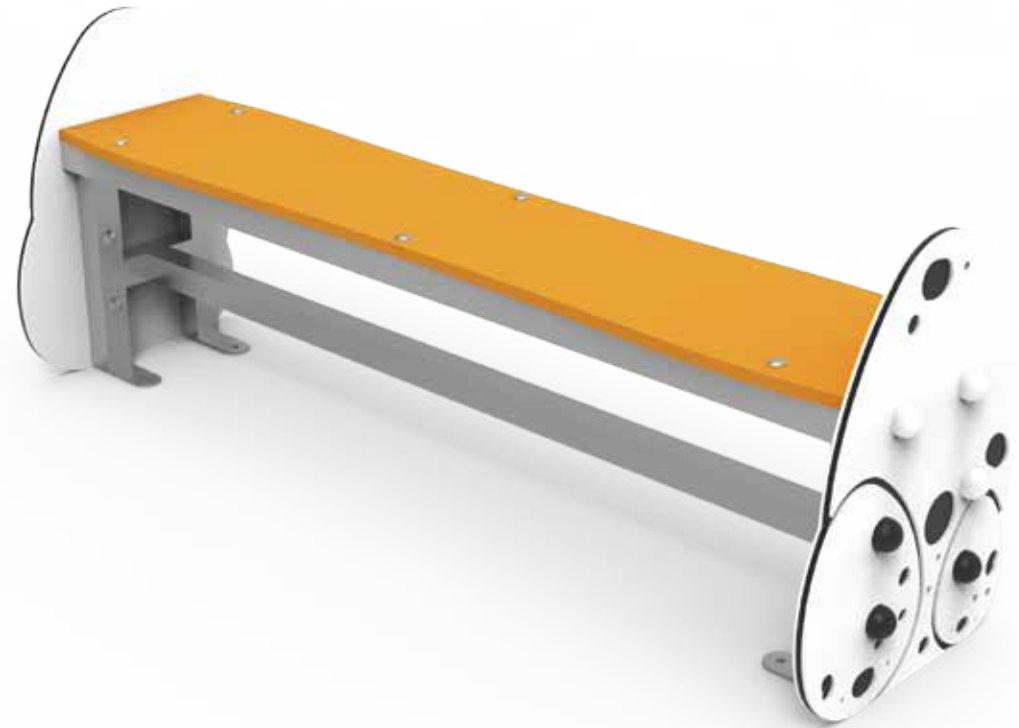

Ref.: JRSCOM03

Banco “ Huevo ”

UNE EN 1176-1:2018

Altura libre de caída: 0,35 m

Edad recomendada de uso: de 0 a 3 años

Componentes plásticos: Polietileno de alta densidad con protección UV

Estructura metálica galvanizada

Tornillería protegida con tapones de polipropileno

ALZADO

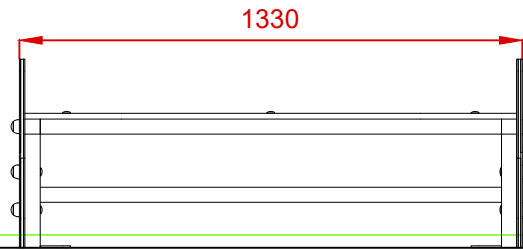

PERFIL

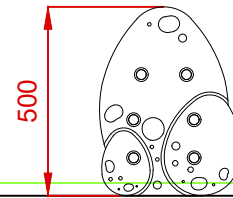

PLANTA

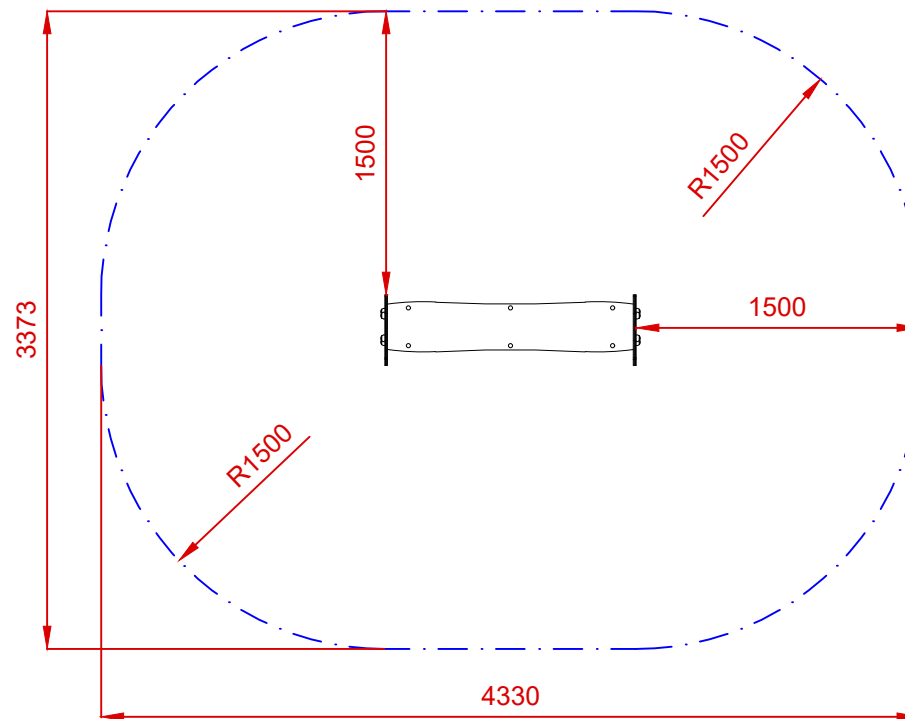
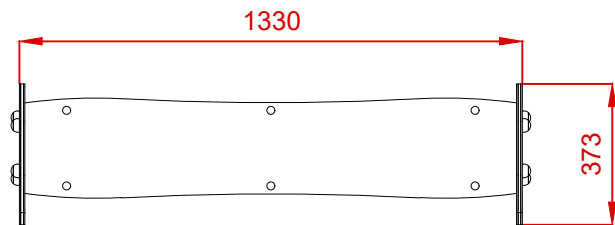

ÁREA DE SEGURIDAD  
Superficie= 12,67m<sup>2</sup>  
E: 1/2

Dibujado		PLANO 1 VISTAS GENERALES		Ref: JRSCOM03
Revisado				
Aprobado				
Descripción:		BANCO "HUEVO"	Escala:	Nº Hoja 2/4
			Fecha:	22/10/2020

# DETALLES CIMENTACIÓN

## ESQUEMA DE CIMENTACIÓN EN ARENA

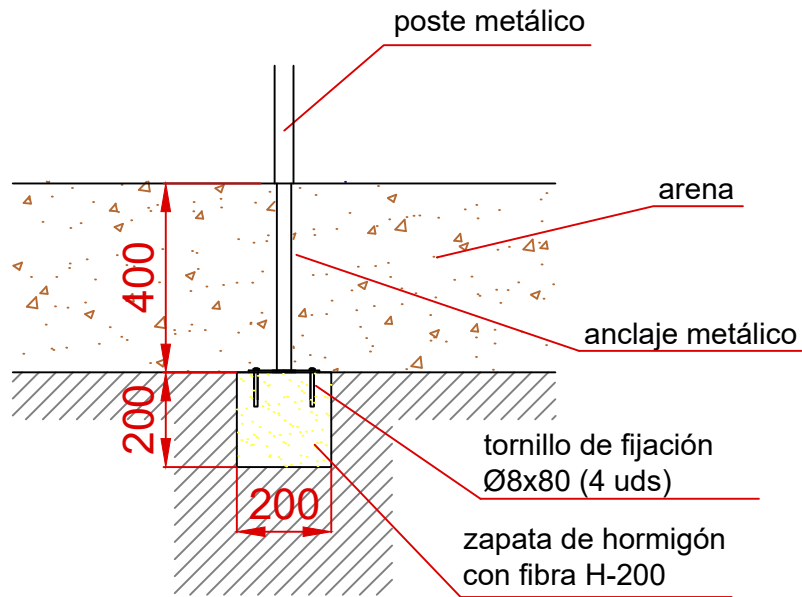

## PLANTA CIMENTACIÓN

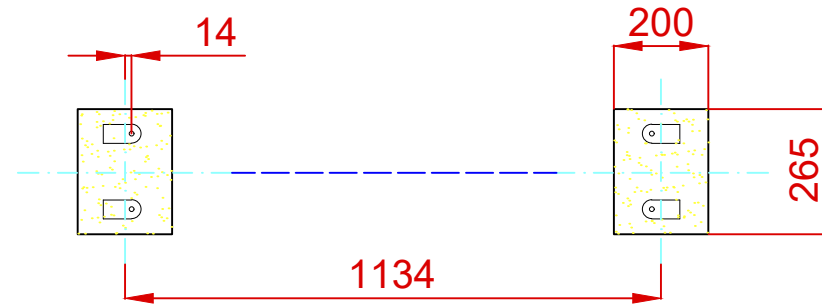

## ESQUEMA DE CIMENTACIÓN EN HORMIGÓN

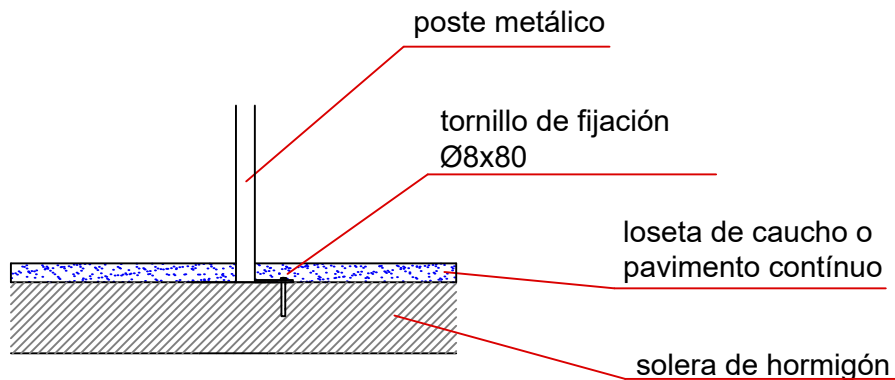

Dibujado		PLANO 2 CIMENTACIÓN Y ANCLAJES		Ref: JRSCOM03
Revisado				
Aprobado				
Descripción:		Escala:	Nº Hoja	
BANCO "HUEVO"			3/4	
		Fecha:	22/10/2020	

### ALZADO

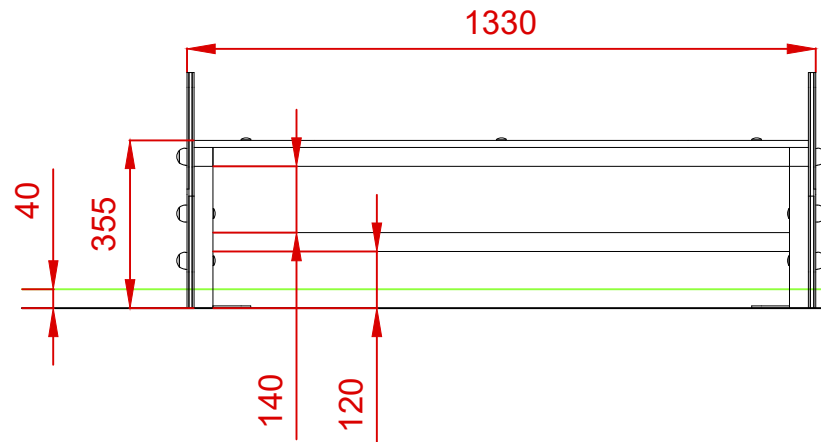

### PERFIL

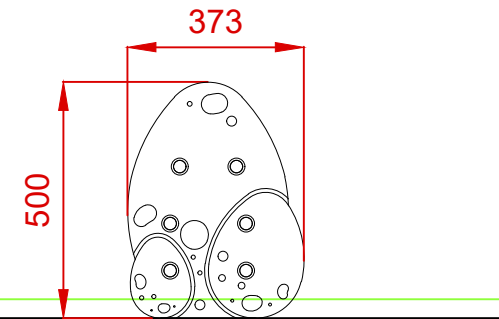

### PLANTA

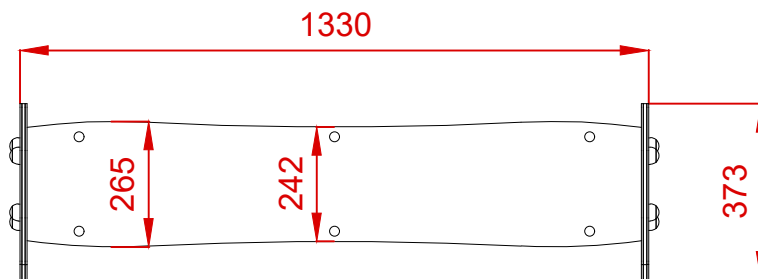

Dibujado		PLANO 3 VISTAS DE DETALLE		Ref: JRSCOM03
Revisado				
Aprobado				
Descripción:	BANCO "HUEVO"		Escala:	Nº Hoja 4/4
			Fecha:	22/10/2020