

DOCUMENTACIÓN TÉCNICA



Ref.: SLVMSP01

Muelle simple “Cebra”

UNE EN 1176-1:2018

UNE EN 1176-6:2018



Altura libre de caída: 0,55 m

Edad recomendada de uso: a partir de 3 años

Componentes plásticos: Polietileno de alta densidad con protección UV

Muelle termolacado con antipinzamiento

Componentes metálicos galvanizados

Tornillería protegida con tapones de polipropileno

ALZADO

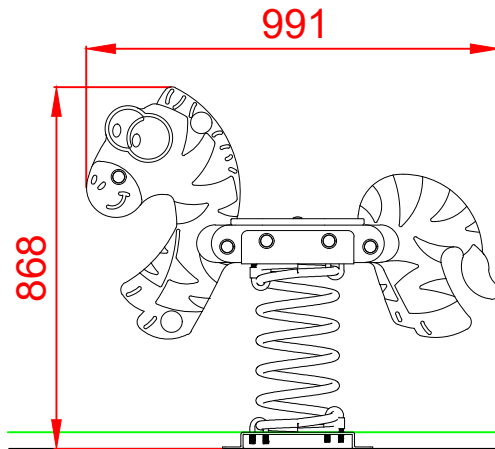

PERFIL

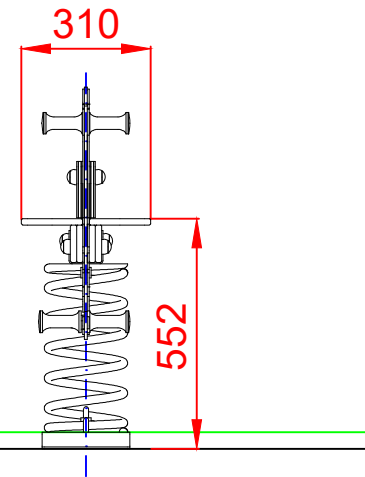

PLANTA

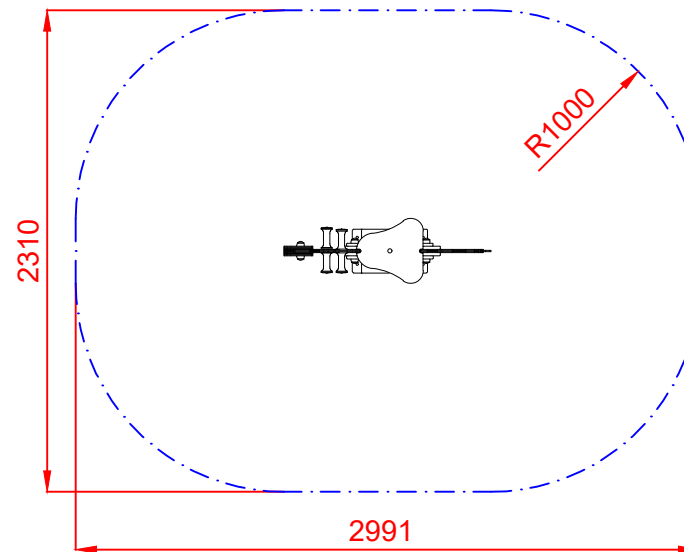
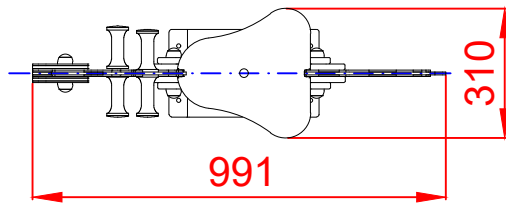

ÁREA DE SEGURIDAD
Superficie= 6,05 m²
E:1/2

Dibujado		PLANO 1		Ref: SLVMSP01
Revisado		VISTAS GENERALES		
Aprobado				
Descripción:		Escala:	Nº Hoja	
MUELLE SIMPLE "CEBRA"			2/4	
		Fecha:	21/10/2019	
				

DETALLES CIMENTACIÓN

ESQUEMA DE CIMENTACIÓN EN ARENA

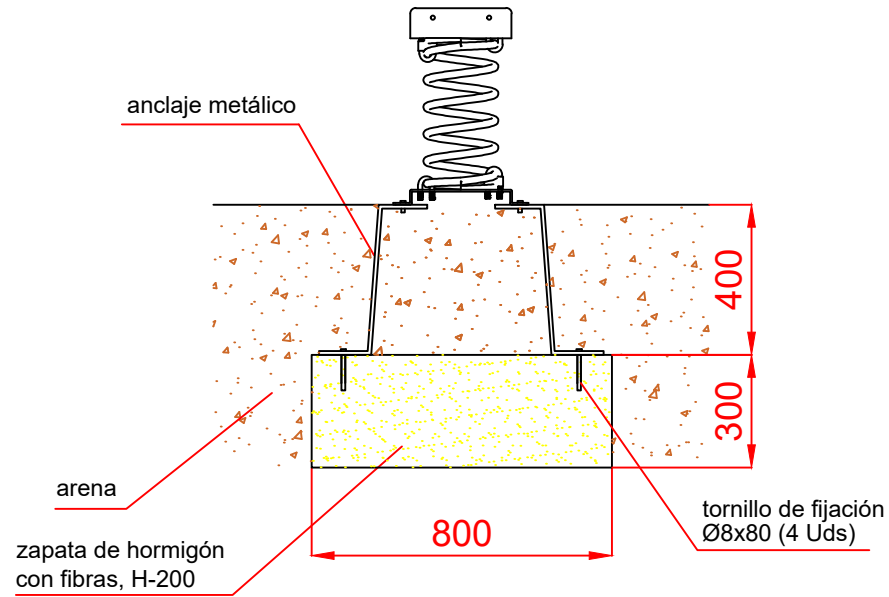

ESQUEMA DE CIMENTACIÓN EN HORMIGÓN

Detalle de sujeción de espirro metálico

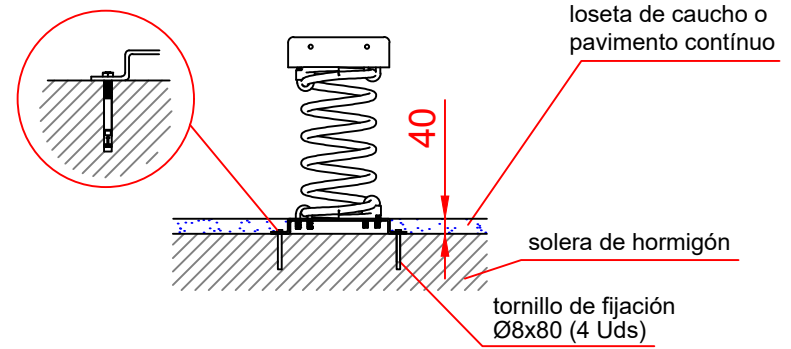

PLANTA

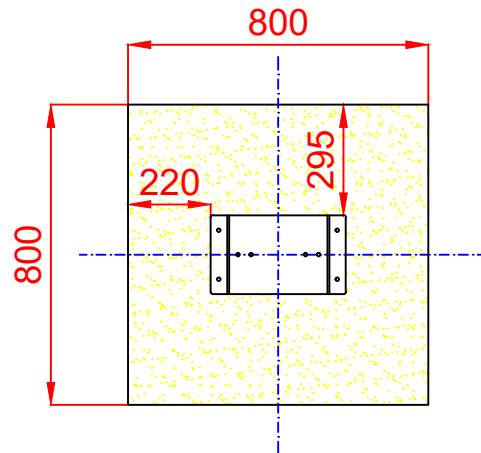

Dibujado		PLANO 2 CIMENTACIÓN Y ANCLAJES	Ref:	SLVMSP01
Revisado				
Aprobado		Descripción:		MUELLE SIMPLE "CEBRA"
		Escala:		Nº Hoja 3/4
		Fecha:	21/10/2019	

ALZADO

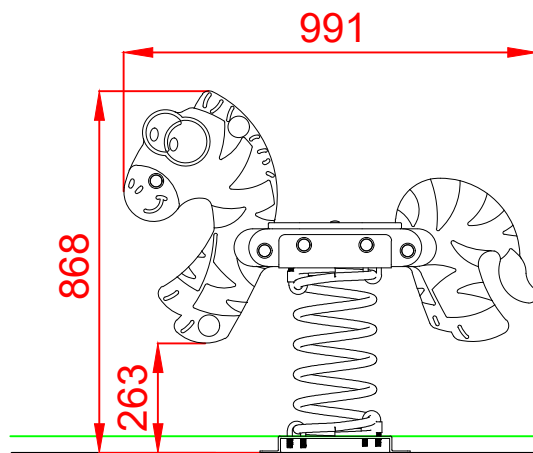

PERFIL

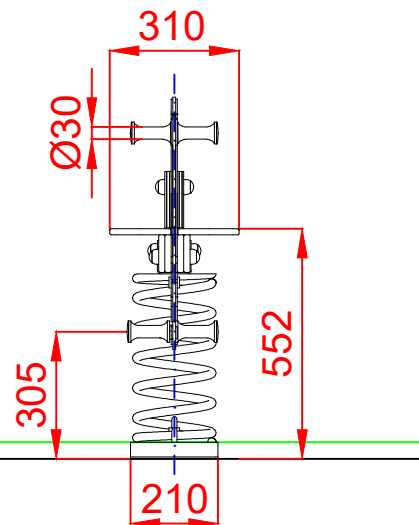

PLANTA

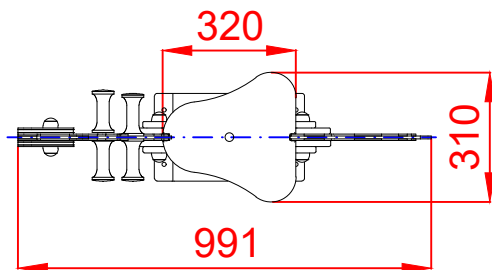

Dibujado		PLANO 3 VISTAS DE DETALLE		Ref: SLVMSP01
Revisado				
Aprobado				
Descripción:	MUELLE SIMPLE "CEBRA"		Escala: N° Hoja: 4/4	Fecha: 21/10/2019