

DOCUMENTACIÓN TÉCNICA

Ref.: CFA001

Arenero Flor

UNE EN 1176-1:2009

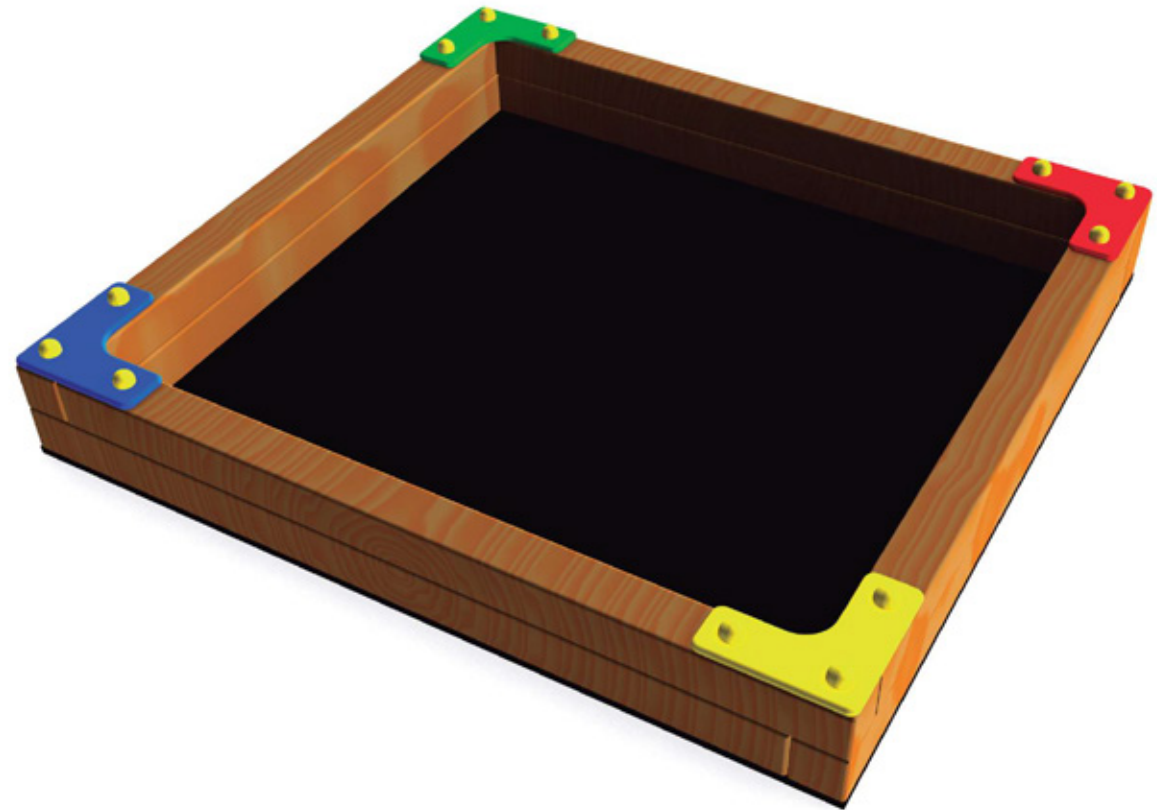

Edad recomendada de uso: de 0 a 3 años
Componentes plásticos: Polietileno de Alta Densidad con protección UV
Tornillería protegida con tapones de polipropileno
Madera tratada en autoclave Nivel IV
Suelo de Panel Finlandés

ALZADO

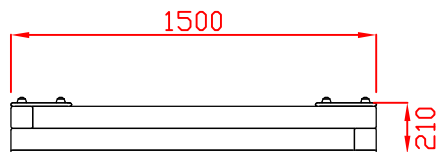

PERFIL IZQUIERDO

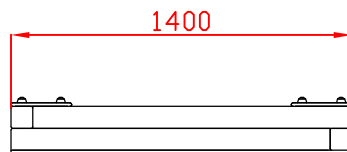

ALZADO POSTERIOR

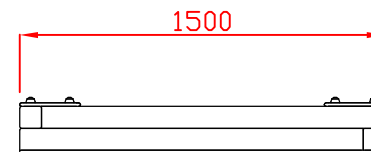

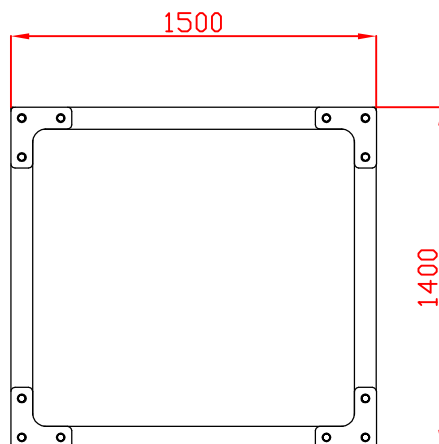

Línea de pavimento

PLANTA

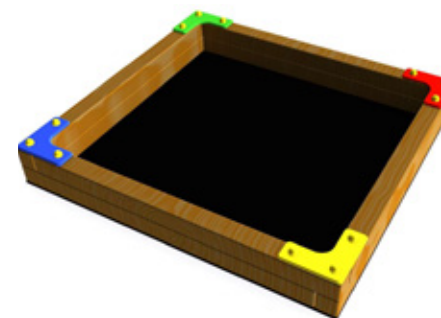
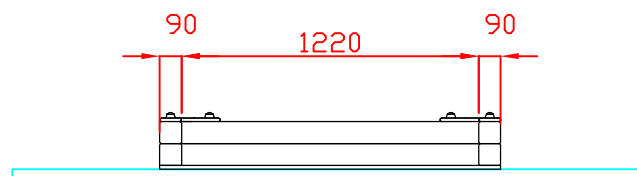

SECCIÓN



Ref:	Cantidad	Designación	Material	Dimensiones
Dibujado		PLANO 1 VISTAS GENERALES	Ref.: CFA001	
Revisado				
Aprobado				
Descripción: ARENERO		Escala:	Peso:	
		Fecha:	03-02-16	

DETALLE DE ANCLAJE ATORNILLADO
 ESCALA 2:1

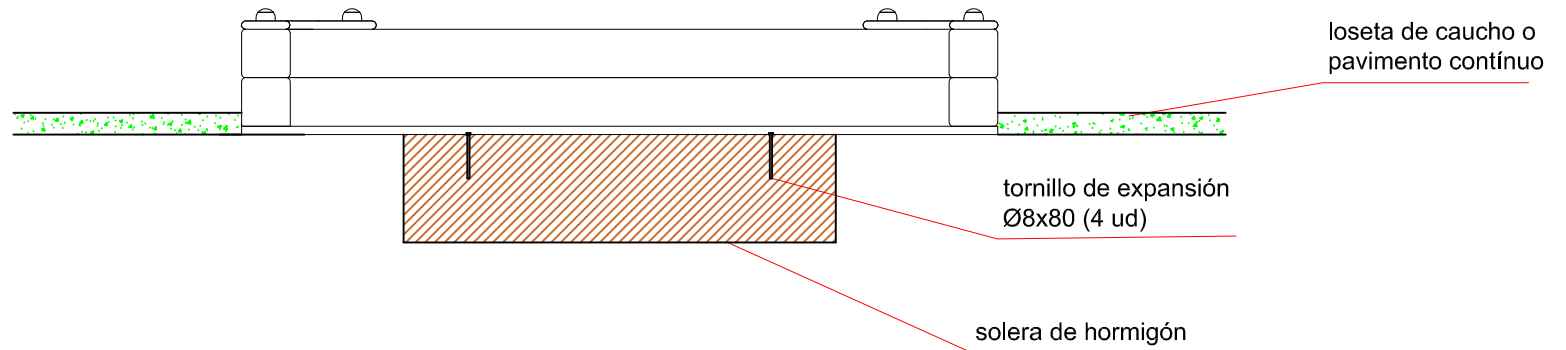

LOSA CIMENTACIÓN 20 CM DE ESPESOR
 ESCALA 2:1

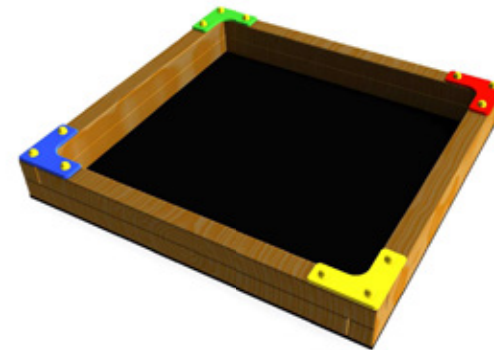
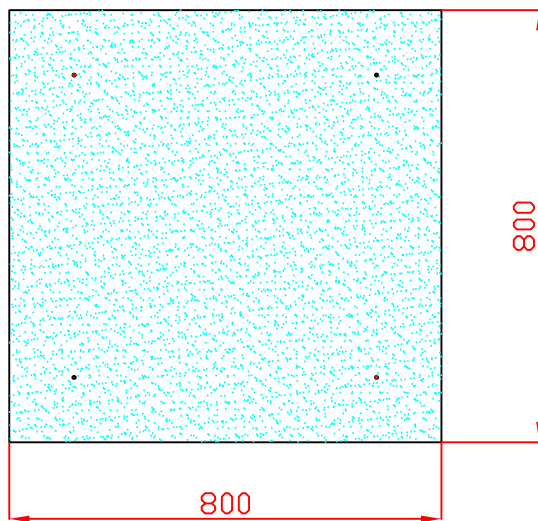

Ref:	Cantidad	Designación	Material	Dimensiones
Dibujado		PLANO 2 CIMENTACIÓN ANCLAJES	Ref.: CFA001	
Revisado				
Aprobado				
Descripción: ARENERO		Escala:	Peso:	
		Fecha:	03-02-16	