

# DOCUMENTACIÓN TÉCNICA



Ref.: SLVMDP01

Muelle doble panel “Camaleón”

UNE EN 1176-1:2018  
UNE EN 1176-6:2018

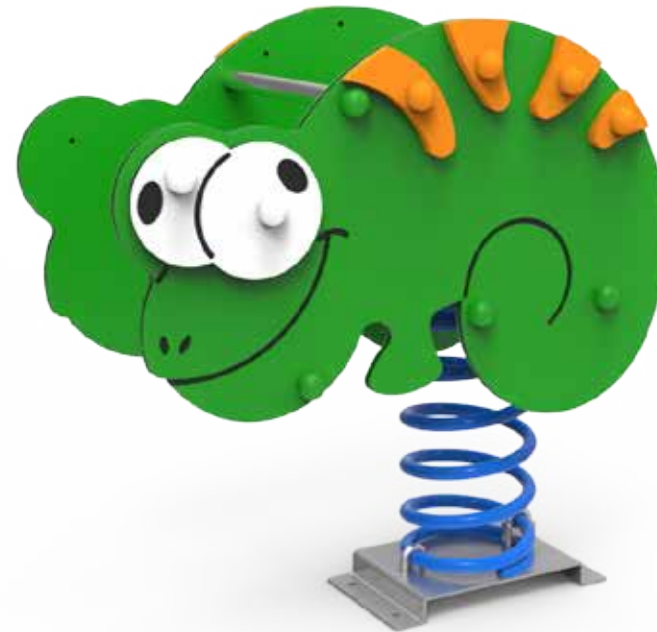

Altura libre de caída: 0,50 m  
Edad recomendada de uso: a partir de 3 años  
Componentes plásticos: Polietileno de alta densidad con protección UV  
Muelle termolacado con antipinzamiento  
Componentes metálicos galvanizados  
Tornillería protegida con tapones de polipropileno

ALZADO

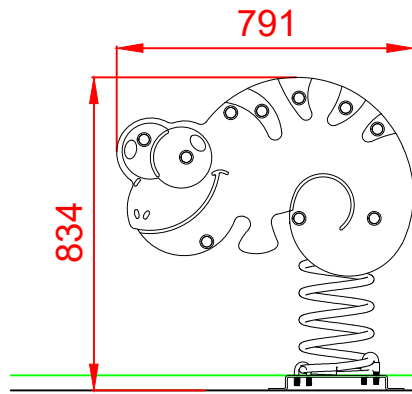

PERFIL

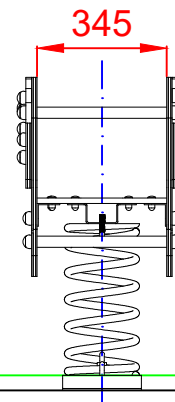

PLANTA

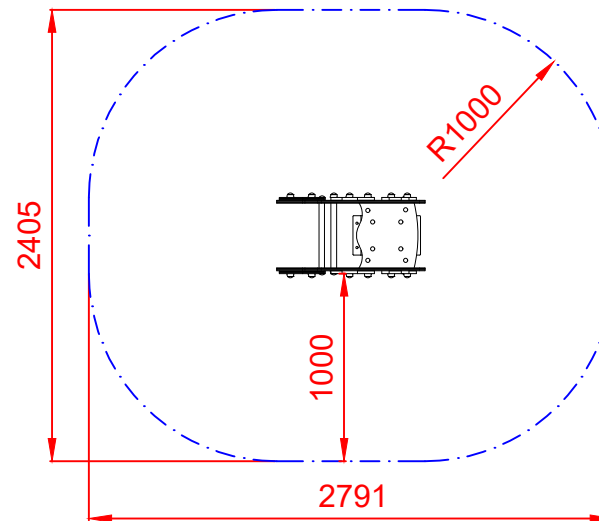
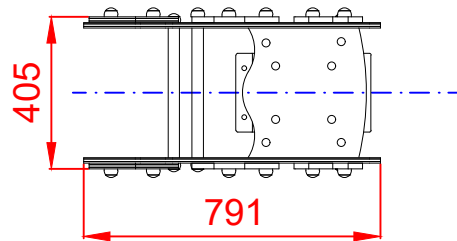

ÁREA DE SEGURIDAD  
Superficie= 5,85 m<sup>2</sup>  
E:1/2

Dibujado		PLANO 1 VISTAS GENERALES		Ref:	SLVMDP01
Revisado					
Aprobado					
Descripción:		Escala:	Nº Hoja		
MUELLE DOBLE PANEL "CAMALEÓN"			2/4		
		Fecha:	16/12/2019		

## DETALLES CIMENTACIÓN

ESQUEMA DE CIMENTACIÓN  
EN ARENA

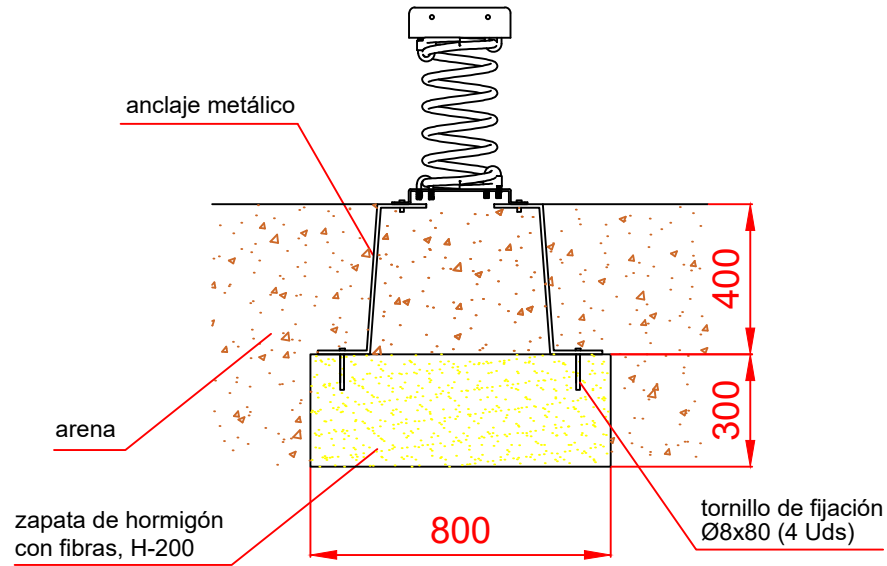

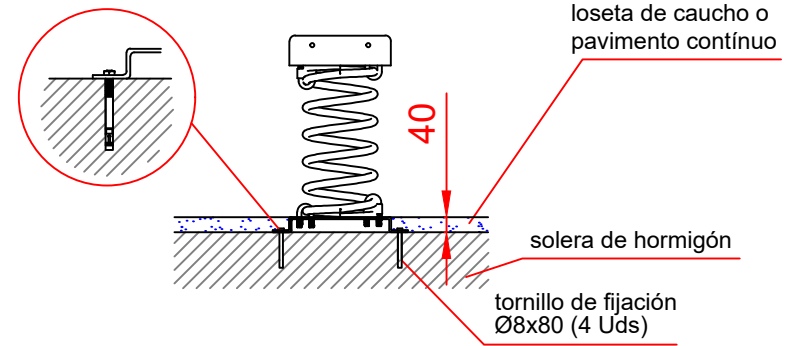

ESQUEMA DE CIMENTACIÓN  
EN HORMIGÓN

Detalle de sujeción de espirro metálico

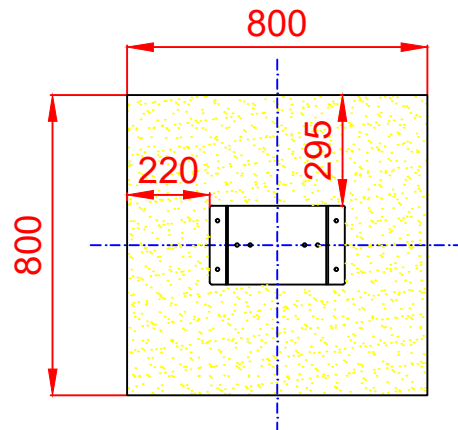

PLANTA



Dibujado		PLANO 2 CIMENTACIÓN Y ANCLAJES	Ref:	SLVMDP01
Revisado				
Aprobado				
Descripción:		Escala:	Nº Hoja	
MUELLE DOBLE PANEL "CAMALEÓN"			3/4	
		Fecha:	16/12/2019	

ALZADO

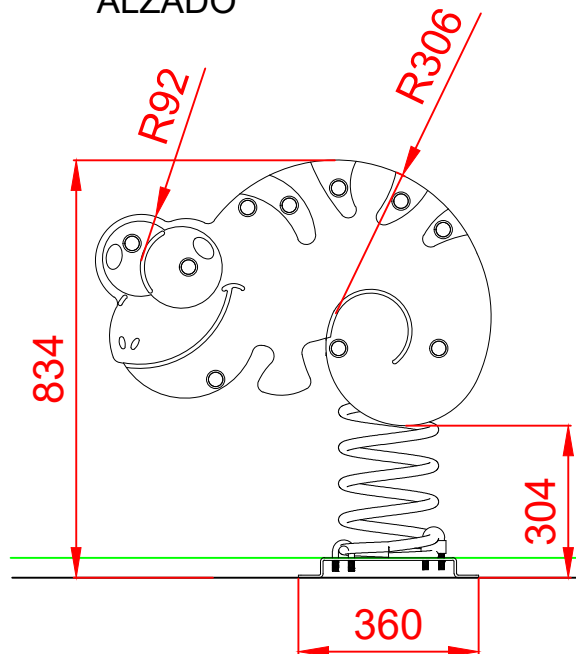

PERFIL

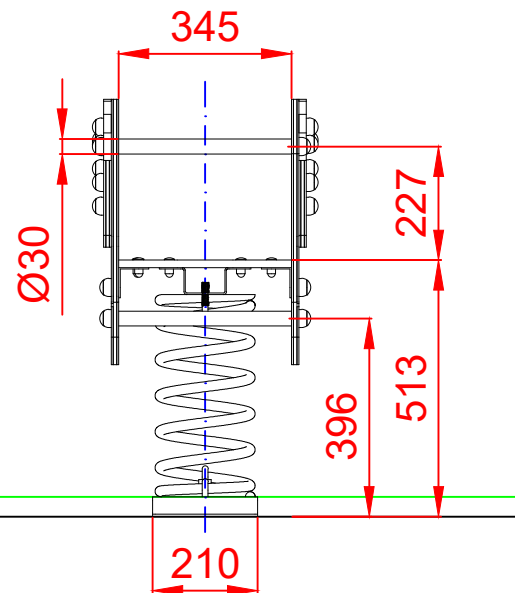

PLANTA

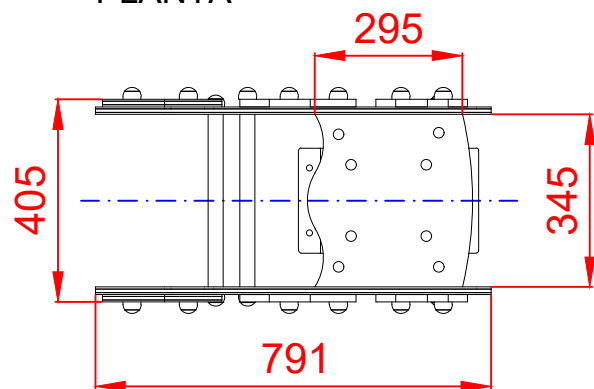

Dibujado		PLANO 3 VISTAS DE DETALLE	Ref:	SLVM DP01
Revisado			 <b>asturmadera</b> Equipamiento Urbano s.l.	
Aprobado				
Descripción:		Escala:	Nº Hoja	
MUELLE DOBLE PANEL "CAMALEÓN"			4/4	
		Fecha:	16/12/2019	