

DOCUMENTACIÓN TÉCNICA

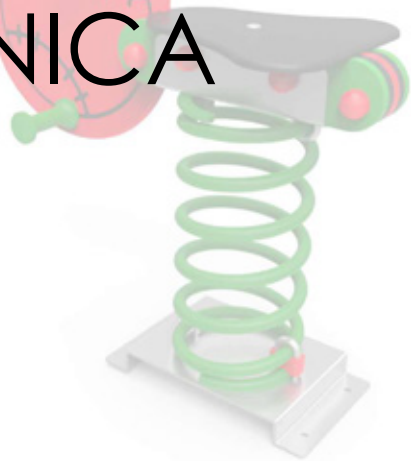

Ref.: M519

Muelle Pelota Béisbol

UNE EN 1176-1:2009

UNE EN 1176-6:2009



SERIE SPORT

am
asturmadera
Equipamiento Urbano s.l.

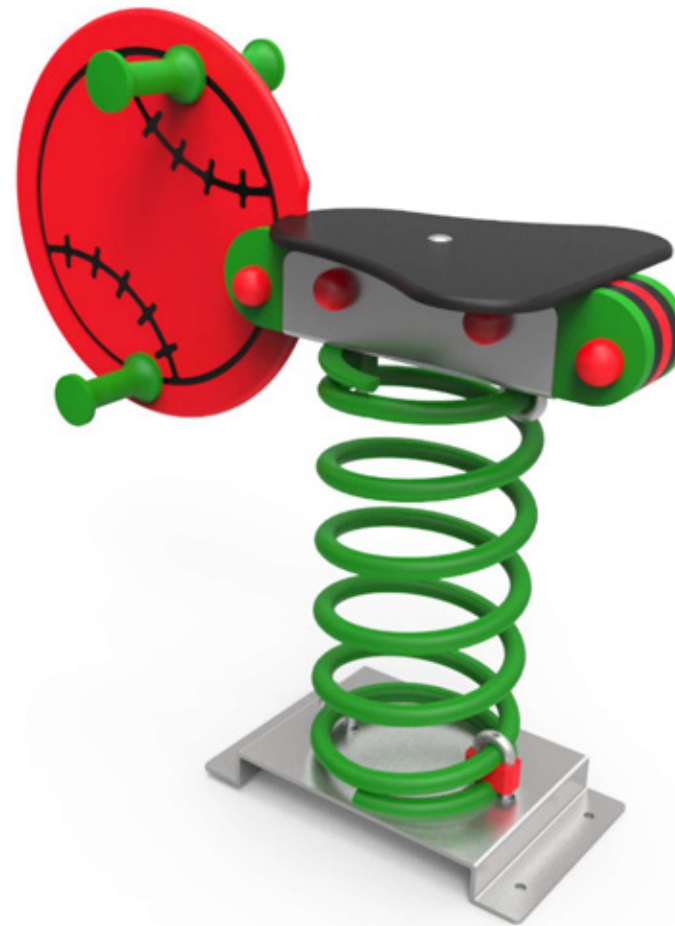

Altura libre de caída: 0,5 m

Edad recomendada de uso: a partir de 3 años

Componentes plásticos: Polietileno de alta densidad con protección UV

Tornillería protegida con tapones de polipropileno

Componentes metálicos galvanizados

Muelle termolacado

ALZADO

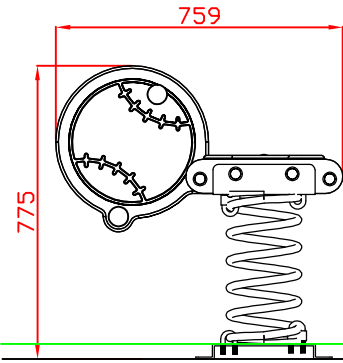

PERFIL IZQUIERDO

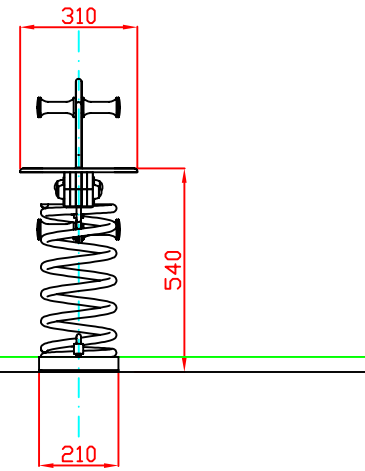

PLANTA

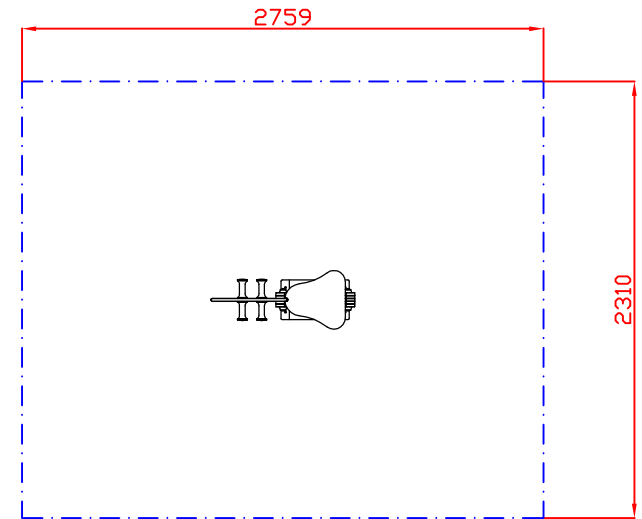
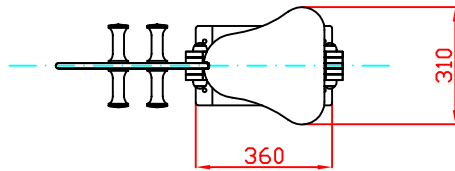

AREA DE SEGURIDAD

Superficie= 6,37 m2

E:1/2



Ref:	Cantidad	Designación	Material	Dimensiones
Dibujado		PLANO 1 VISTAS GENERALES	Ref: M519	 asturmadera Equipamiento Urbano s.l.
Revisado				
Aprobado				
Descripción:		Escala:	Peso:	
MUELLE SIMPLE PELOTA "BEISBOL"		Fecha:	05-03-18	

DETALLES DE CIMENTACIÓN

EN ARENERO

ALZADO

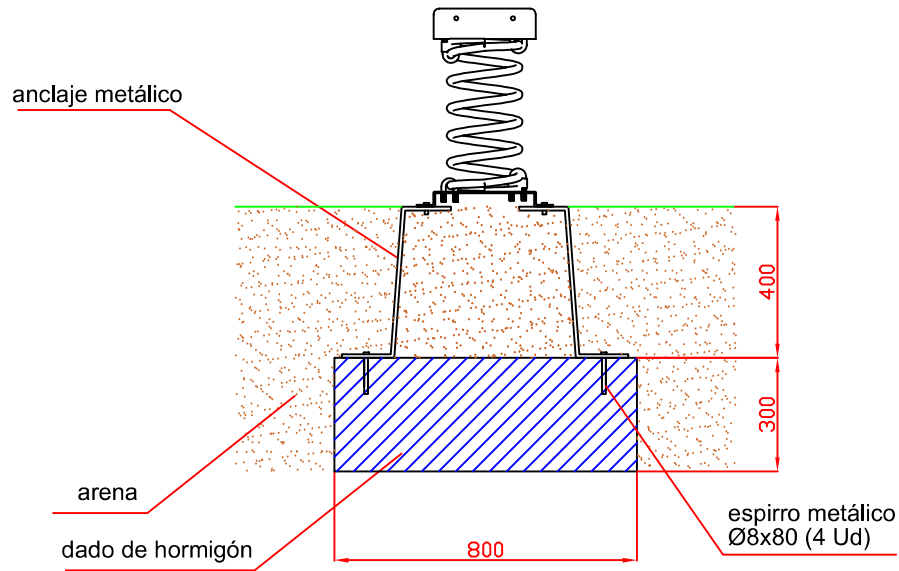

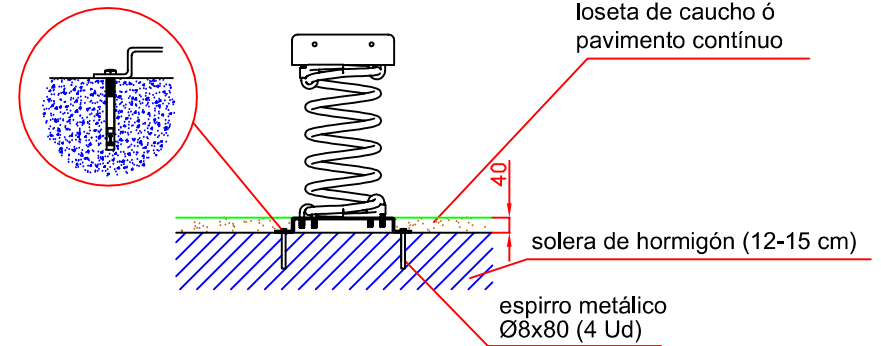

SOBRE HORMIGÓN

Detalle de sujeción de espirro metálico

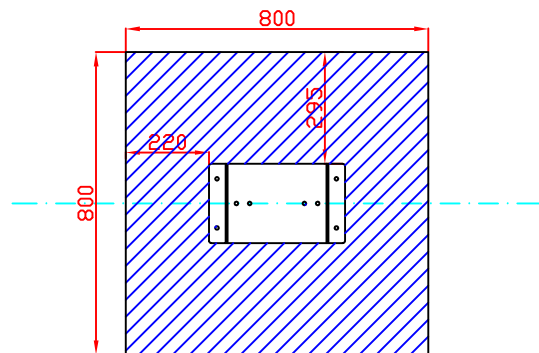

PLANTA



Ref:	Cantidad	Designación	Material	Dimensiones
Dibujado		PLANO 2 CIMENTACIÓN Y ANCLAJES	Ref: M519	
Revisado				
Aprobado				
Descripción:		Escala:	Peso:	
MUELLE SIMPLE PELOTA "BEISBOL"		Fecha:	05-03-18	