

# DOCUMENTACIÓN TÉCNICA

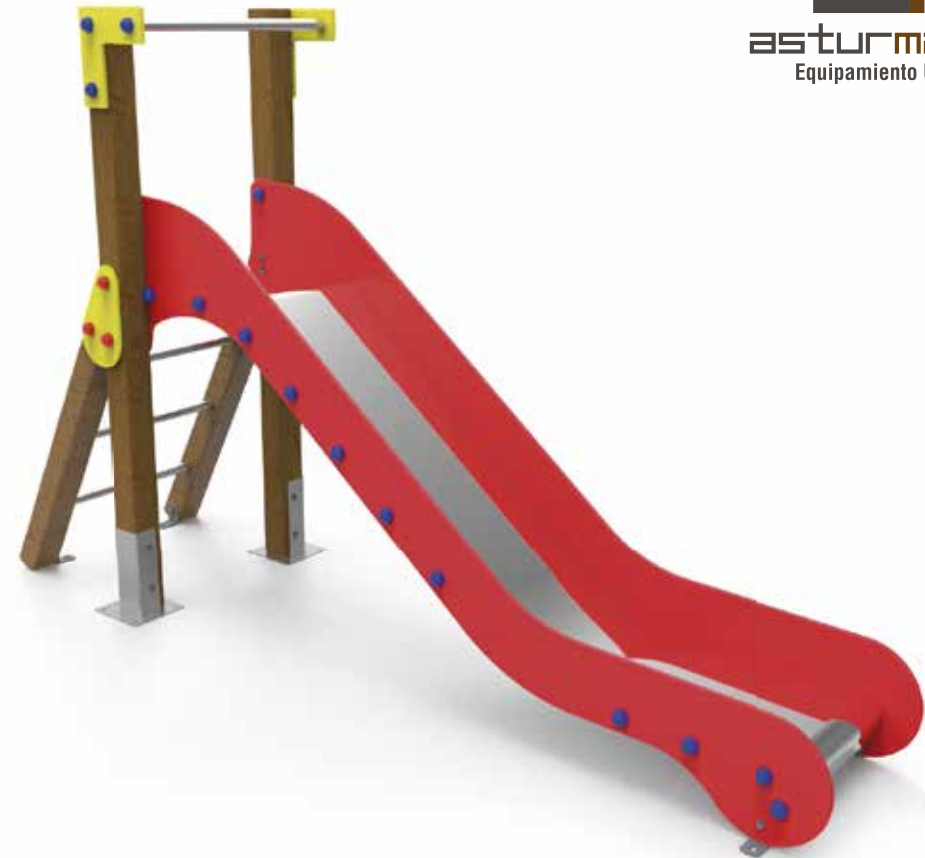

Ref.: TBG07

Tobogán "Quipar Mini"

UNE-EN 1176 -3:2018



Altura libre de caída: 0,90 m  
Edad recomendada de uso: a partir de 3 años  
Componentes plásticos: Polietileno de alta densidad con protección UV  
Rampa de tobogán: acero inoxidable  
Tubo superior: acero inoxidable  
Tornillería protegida con tapones de polipropileno  
Madera de pino tratada en autoclave Nivel IV

ALZADO

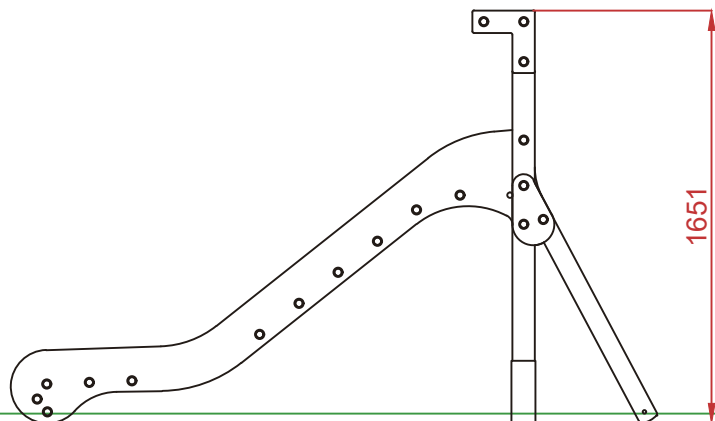

PERFIL

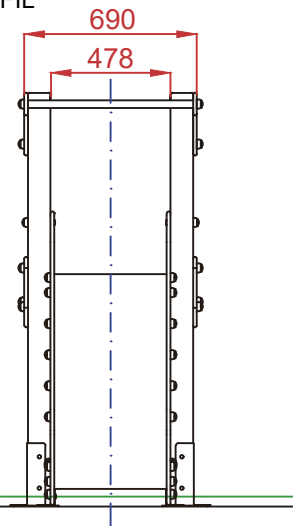

PLANTA

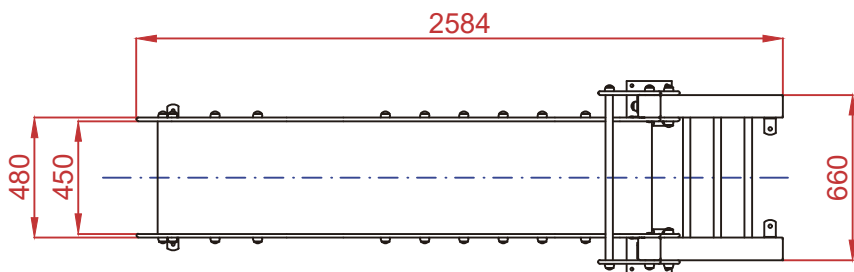

ÁREA DE SEGURIDAD  
Superficie= 17.1 m<sup>2</sup>  
E: 1/2

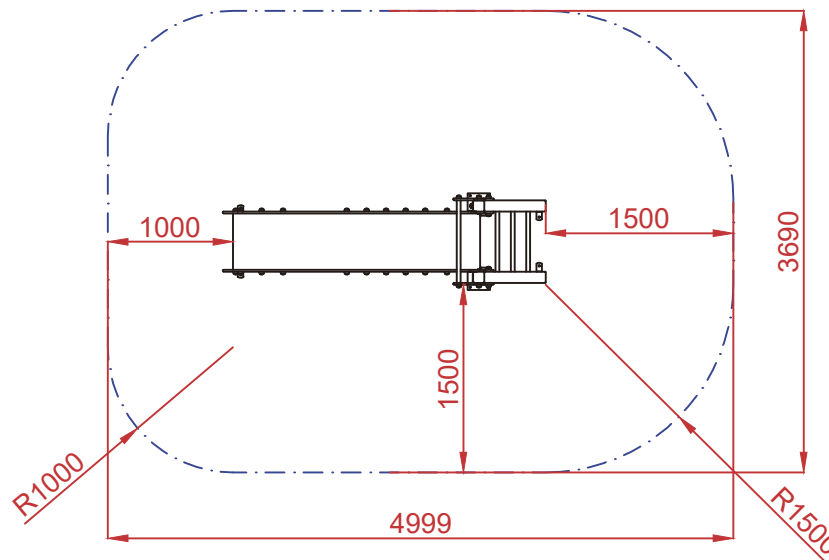

Dibujado		PLANO 1 VISTAS GENERALES		Ref: TBG07
Revisado				
Aprobado				
Descripción:	TOBOGÁN "QUIPAR MINI"		Escala:    Nº Hoja Fecha: 07/05/2019    2/4	

# DETALLES CIMENTACIÓN

ESQUEMA DE CIMENTACIÓN  
EN ARENA  
E: 2/1

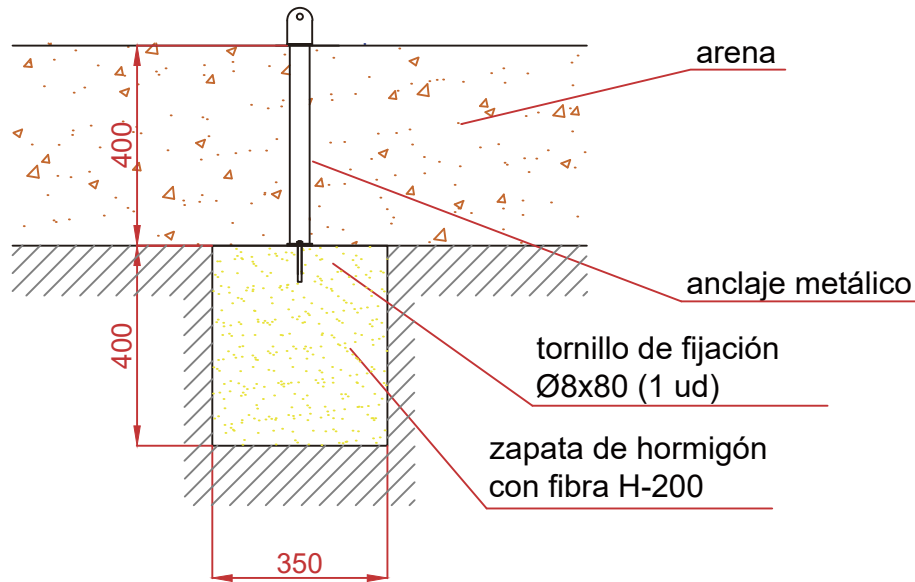

PLANTA CIMENTACIÓN

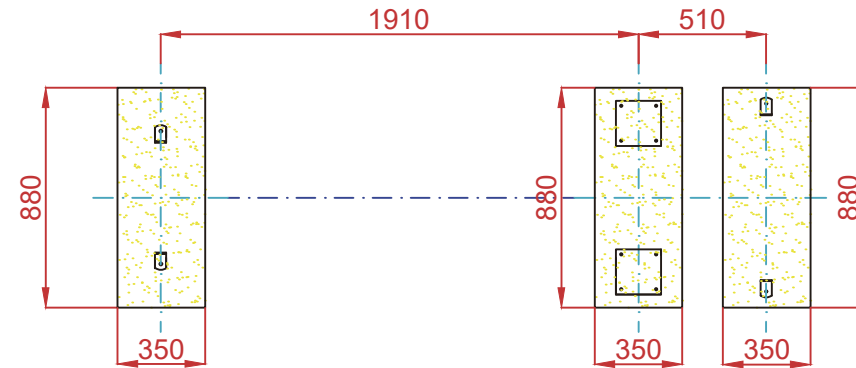

ESQUEMA DE CIMENTACIÓN  
EN HORMIGÓN  
E: 2/1

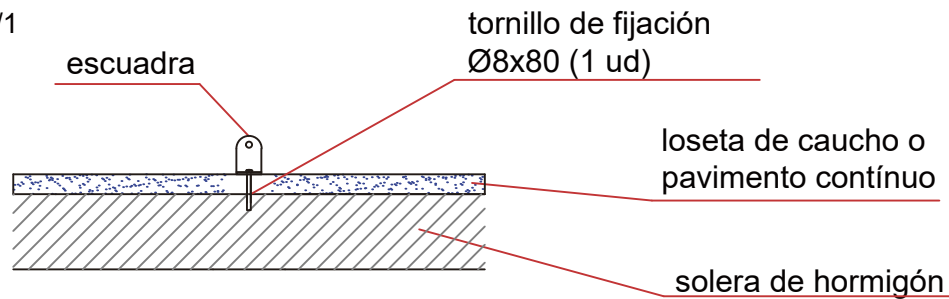

Dibujado		PLANO 2		Ref: TBG07
Revisado		CIMENTACIÓN Y ANCLAJES		
Aprobado				
Descripción:		Escala:	Nº Hoja	
TOBOGÁN "QUIPAR MINI"			3/4	
		Fecha:	07/05/2019	



ALZADO

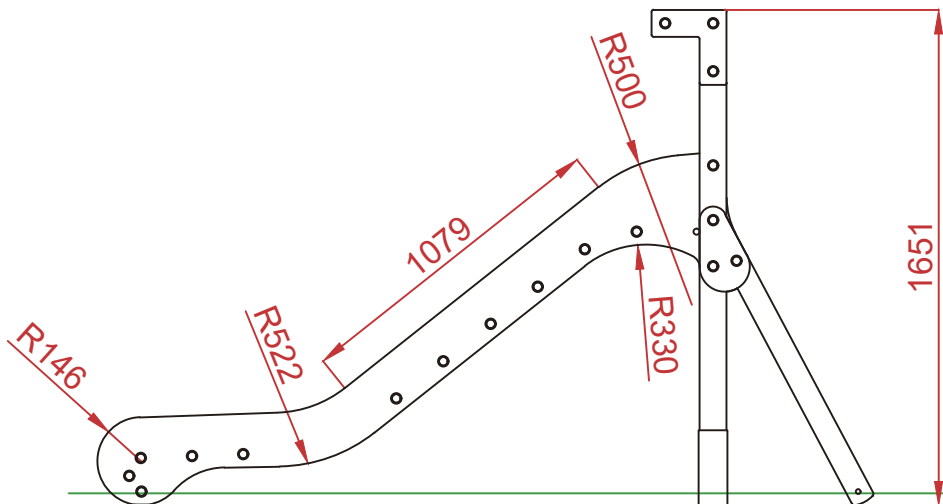

PERFIL

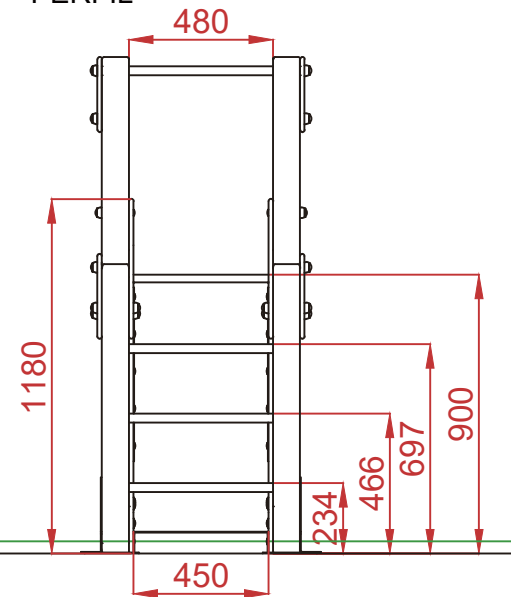

PLANTA

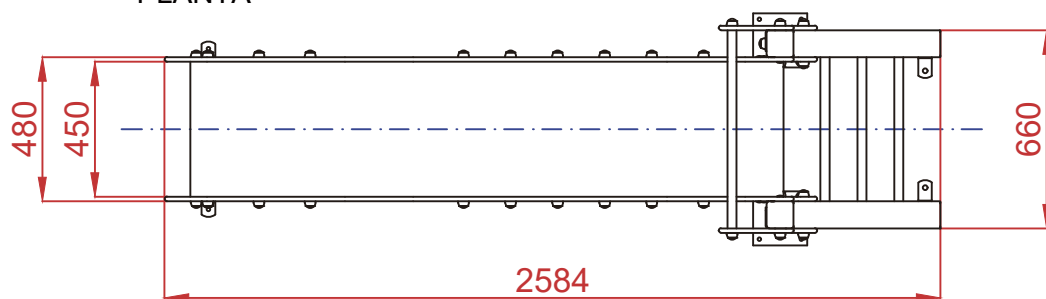

Dibujado		PLANO 3 VISTAS DE DETALLE		Ref: TBG07
Revisado				
Aprobado				
Descripción:		TOBOGÁN "QUIPAR MINI"	Escala:	Nº Hoja 4/4
			Fecha:	07/05/2019